

The New SURELOK III

25" Throat Machine

Designed for all clinching applications

With its versatile design and unsurpassed features the Surelok III series of machines outperform the competition like no other.

Solid and reliable, the Surelok III will fasten material from as thick as 14 gauge to as thin as 32 gauge with our proven clinching technology.

Superior Features include...

APU - Advanced Power Unit

- faster, smoother, quieter and uses less air

Stainless steel ready

- with a simple punch and die change

Adjustable 2 1/2" (63mm) stroke

- convenience of use

15 years of design experience

- proven reliability and quality

Air powered

- requires no electrical hookup

When you combine all the features, benefits and quality, the Surelok III sets the standard by which other clinching machines are measured.

**Join the
"clinching revolution"**

26 Adams Boulevard
Brantford, ON N3S 7V2
519-759-5896 www.norlok.com



NORLOK
TECHNOLOGY INC.
Setting the standards

SPECIFICATIONS – SURELOK III

- Press Design:** Solid 3" (76mm) steel "C" frame.
Rigid steel frame = longer tool life
- Features:** APU pneumatic power unit.
Regulator, Shut-off valve
Foot pedal operated
- Stroke:** 2 1/2" (63mm) max. (adjustable)
"Intelligent" safety stroke for greater operator safety.
- Throat:** SL 25" (635mm)
Work Height: 45" (1143mm)
- Upper Tooling:** Round or Rectangular ready
Close tooling access allows for more applications.
Simple adjustments to suit material thickness.
- Lower Tooling:** Die insert on a hardened die plate with a hardened protection collar.
- Capacity:** MAX: 2 ply .075" (1.9mm) mild steel.
MIN: 2 ply .010" (.25mm) mild steel.
MAX: 2 ply .050" (1.25mm) Stainless.
MIN: 2 ply .010" (.25mm) Stainless.
(Rectangular tooling for stainless)
- Cycle speed:** 60-80 cycles/minute (standard)
85 to 120 cycles/minute with options
- Air Requirements:** 80psi to 100psi (5.4 - 6.8 Bar)
100psi (6.8 Bar) (recommended)
Approx .2 cu ft (.0056 cu m) free air per cycle.
2 HP (1.5 kW) @ 60 clinches per min.
- Weight:** SL 25: 1300 lb (591kg)

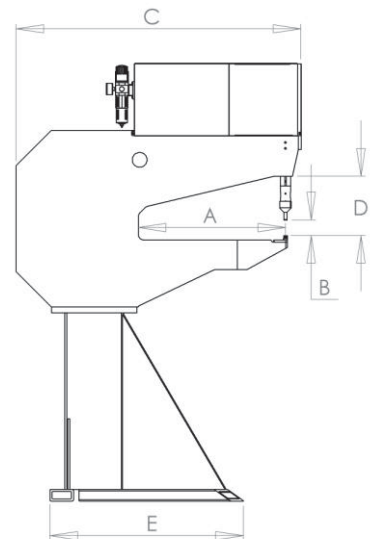

SL 25	
A	25" [635mm]
B	2.5" [63mm]
C	48.5" [1232mm]
D	10" [254mm]
E	33" [838mm]
F	37.5" [953mm]
G	45" [1143mm]
H	74.5" [1892mm]

Typical Joint Strengths in Mild Steel:

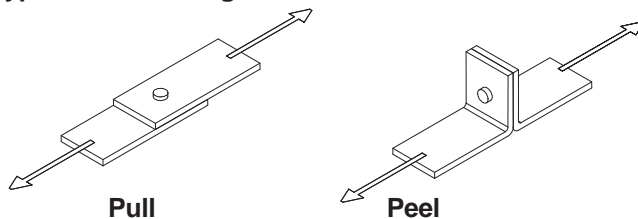

Material Thickness" (mm)	Pull lbs(N)	Peel lbs(N)	Die Type
.075 (1.9)	550 (2447)	225 (1001)	#50
.060 (1.5)	475 (2113)	175 (778)	#50
.050 (1.25)	430 (1913)	150 (667)	#40/#50
.040 (1.0)	400 (1779)	120 (534)	#40
.034 (.86)	375 (1668)	100 (445)	#30/#40
.028 (.71)	325 (1446)	85 (378)	#30
.022 (.55)	285 (1268)	70 (311)	#30

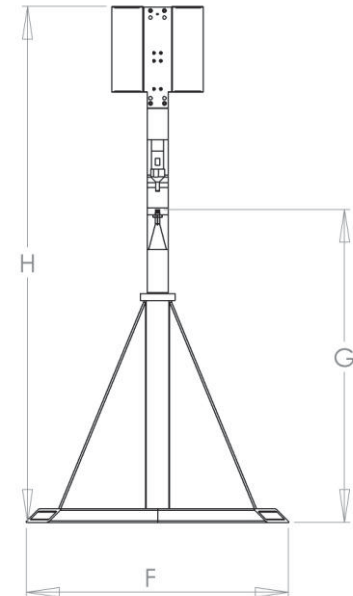

Pipe diameter	Die reach into Pipe
3" (76mm) Ø	1-3/8" (34.9mm)
4" (102mm) Ø	3 1/4" (82.5mm)
5" (127mm) Ø	5" (127mm)
6" (152mm) Ø	12-1/4" (311mm)
7" (178mm) Ø	13-5/8" (346mm)
8" (203mm) Ø	15-7/8" (403mm)
9" (229mm) Ø	18-1/8" (460mm)
10" (254mm) Ø	20-1/2" (521mm)*
11" (279mm) Ø	22-3/4" (578mm)*
12" (305mm) Ø	24-1/2" (622mm)*