

The SURELOK II

18" or 25" Throat Machine Designed for standard clinching applications

With its versatile design and unsurpassed features the Surelok II series of machines outperform the competition like no other.

Solid and reliable, the Surelok II will fasten material from as thick as 14 gauge to as thin as 32 gauge with our proven clinching technology.

Superior features include ...

Rigid steel frame

- ▶ less deflection for longer tool life

Close tooling access

- ▶ get in close for more applications

Fast cycle times

- ▶ for more production

18" or 25" throats

- ▶ greater reach for larger parts

"Intelligent" safety stroke

- ▶ for greater operator safety

Direct acting power stroke

- ▶ for more reliable joints

Simple tool adjustments

- ▶ little or no setup time

Adjustable stroke

- ▶ Reduces pinch point and air consumption

Completely upgradeable

- ▶ add what you need - when you need it

Small footprint

- ▶ requires less floor space

10 years of design experience

- ▶ proven reliability and quality

Air powered

- ▶ requires no electrical hookup

Affordable prices

- ▶ low investment and faster payback

When you combine all the features, benefits and quality, the Surelok II sets the standard by which other clinching machines are measured.

NORLOK
TECHNOLOGY INC.
Setting the standards



SPECIFICATIONS – SURELOK II

- Press Design:** Solid 3" steel "C" frame.
- Features:** WAMP pneumatic power unit.
Air surge tank and regulator
Foot pedal operated
- Stroke:** 1" max. (adjustable)
- Throat:** 18" or 25"
- Work Height:** 45"
- Upper Tooling:** 3 Types available.
See features chart for details.
Adjustable to suit material thickness.
- Lower Tooling:** Die insert in a 2-piece hardened die plate.
- Capacity:** MAX: Two ply 0.075" mild steel.
MIN: Two ply 0.010" mild steel.
- Cycle speed:** 60-80 cycles/minute (standard)
Up to 160 cycles/minute with options
- Air Requirements:** 80psi to 125psi
125psi (recommended)
Approx. 0.6 cu ft free air per cycle.
(5 HP @ 60 clinches per minute)

Dimensions:

	Surelok18	Surelok25
Width	36"	36"
Length	39"	51"
Height	73"	73"
Weight	800 lbs	1600 lbs

Typical Joint Strengths (Mild Steel):

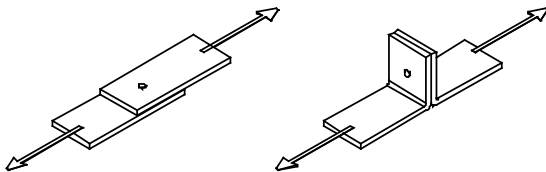

Pull

Peel

Material Thickness	Pull (lbs)	Peel (lbs)	Die Type
0.075" (14g)	550	225	#50
0.060" (16g)	475	175	#50
0.050" (18g)	430	150	#40/#50
0.040" (20g)	400	120	#40
0.034" (22g)	375	100	#30/#40
0.028" (24g)	325	85	#30
0.022" (26g)	285	70	#30

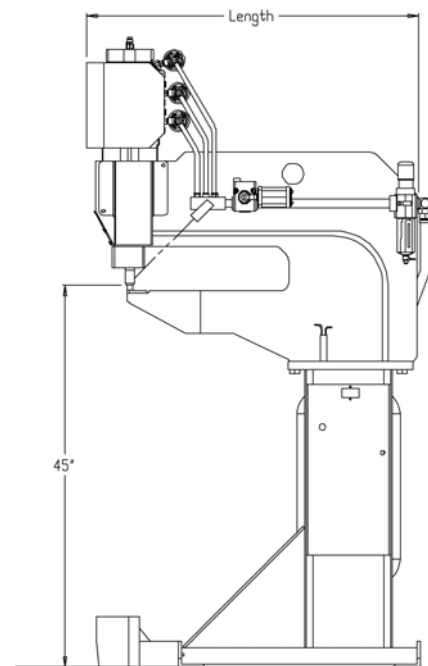
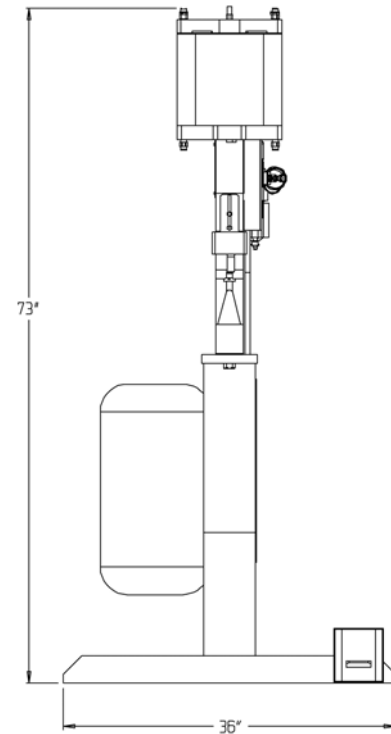

Pipe diameter Die reach into Pipe

3" Ø	1-3/8"
4" Ø	3 1/4"
5" Ø	5"
6" Ø	12-1/4"
7" Ø	13-5/8"
8" Ø	15-7/8"
9" Ø	18-1/8"
10" Ø	20-1/2" *
11" Ø	22-3/4" *
12" Ø	24-1/2" *

*Surelok II 25" throat only

Surelok II Frame & Tooling Detail

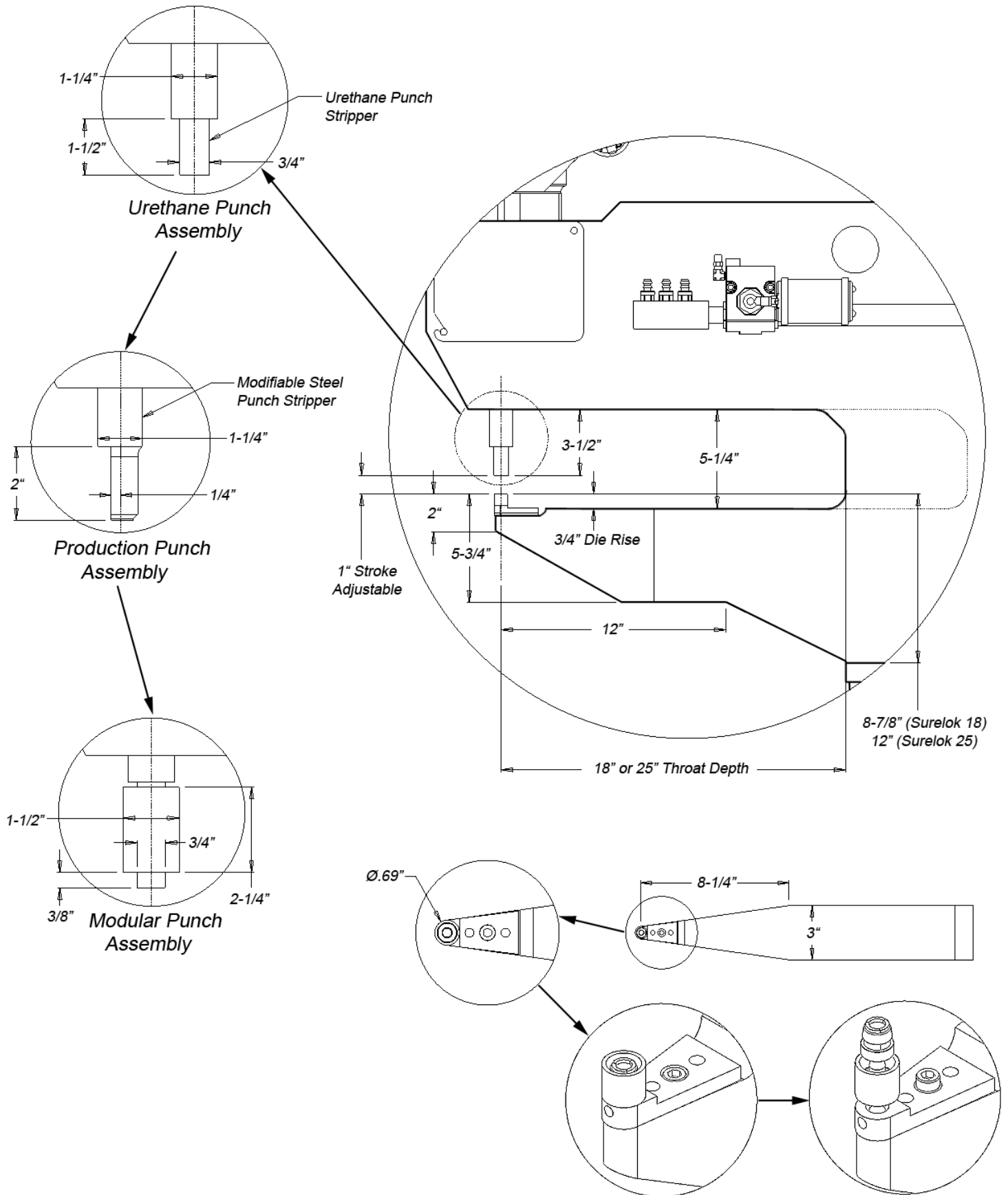

The SURELOK II

Features and Options

The Surelok II machines come in 2 varieties

E series Entry level affordability with urethane punch stripper assembly

P series Performance with production tooling, laser pointer, high speed control and 2 free dies.

STANDARD FEATURES	
Throat 18" or 25"	Choose the depth of frame behind punch
Urethane punch assembly	Reliable tooling with urethane stripper
Close reach lower arm	Clinch in tight areas – also great for pipes
2 piece die holder and insert	Fast to change and easy to clean
Adjustable stroke	Adjust open height to minimize pinch point
"Intelligent" Safety stroke	Reduces pinch point to less than 1/4" even with 1" stroke - includes self checking circuits for added safety
Lexan guard	Eye protection without restricting access
Air surge tank	Minimizes the effects of poor air supply
Air filter / regulator	Nothing to add - just plug your air line into the tank
Frame mounted tool kit	All tools required for adjustments are included

OPTIONS	Series			✓ included ● available	
		E	P		
Production punch assembly [P]		●	✓	Our best tooling with longest punch and die life, best part access, best material range, and easily modified.	
Modular punch assembly [M]		●	●	Modular tooling is best for stainless steel. Either lance (SS) or round punches can be installed.	
Auto return [R]		✓	●	Automatic (timed) press return - adjustable to suit application and air pressure	
Advanced power unit [A]		✓	✓	A fast, production oriented power unit - increases press speed by approximately 10%	
Extended Warranty [X]		●	✓	Extends standard warranty to 3 years (punches and dies excluded)	
High speed control [H]		●	✓	1 touch operation with increased speed & reliability - includes pressure sensing circuit.	
Laser pointer [L]		●	✓	Shows where clinch will be made – easy to use - meets all regulations for laser pointers	
Side table [T]		●	●	12" x 18" swivel table - great for holding small parts and tools	

Examples of Surelok II Model Numbers

SLII E-18-L "Entry" series 18" with Laser Pointer

SLII P-25 "Performance" series 25"



26 Adams Boulevard, Brantford, Ontario, Canada N3S 7V2

519.759.5896 Fax: 519.759.2948

Email: info@norlok.com Web: www.norlok.com

SPECIALISTS IN CLINCHING TECHNOLOGY

An ISO 9001 Registered Company

DISTRIBUTED BY

Fabricating Machinery, Inc.

6315 Toronto St.

Dallas, TX, 75212

(214) 688-0472

sales@fabmachine.com