

May 6, 2020

CYBEND HYDRAULIC PRESS BRAKE “HYBRID” GADE SPC-H



Your contact person(s):

Fabricating Machinery, Inc.
6315 Toronto St.
Dallas, TX, 75212
(214) 688-0472
Dan@FabMachine.com



100% MADE IN ITALY

CYBEND System description

The principle of the "HYBRID" series press brake is based on a cylinder control system carried out by two independent groups consisting of BRUSHLESS MOTORS + REVERSIBLE INTERNAL GEAR PUMP (each group controls one cylinder only).

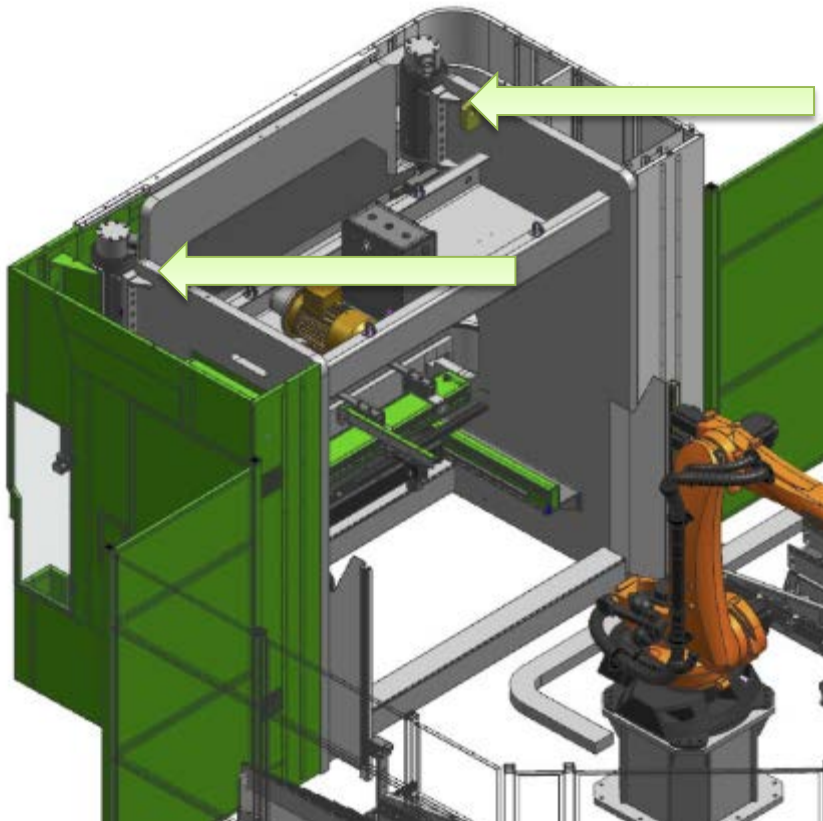

The advantages given by this system are:

- Energy saving obtained by the low consumption of brushless motors which, moreover, remain "on" ONLY during the working cycle.
- The lack of DIRECTIONAL proportional valves which allows to completely eliminate the oil heating and, consequently, there is no need to install the heat exchanger. Also, a minimal amount of circuit fluid is required.
- Position accuracy of Y1, Y2 axes 0.001 mm.
- High approaching, return and bending speed.
- Noiseless operation even during the bending process.



Base in monolithic welded structure with milling and reaming in a single position on a mobile column boring machine.

Sliding lower beam with sandwich system (picture on the left) for the hydraulic compensation (picture on the right) of the flexion of the ram and the lower beam itself (ACTIVE HYDRAULIC CROWNING).

This guarantees the maximum precision of the bending angle over the entire length of the piece.



Electronic movement measurement system of the upper beam (Y1 - Y2 axes) made with digital linear transducers installed in such a way as to totally eliminate the negative effect of the flexures on the sides that can be seen with the use of the machine.



The sliding guides of the machine (mainly top beam) are made by anti-friction gibs which are totally free from being wear.

The main hydraulic cylinders are of the "double effect" type with lapped barrel and piston being induction hardened, grounded, chromed and polished.



Increased bending speed thanks to LazerSafe's IRIS system, supplied as standard with all the press brakes of this series. The machine, in accordance with the sheet angular speed during the bending process, can reach the linear speed of 23 mm/sec (54 ipm).

Improved dynamics and lower machine downtime thanks to speed change set at ZERO mm from the sheet plate.



The machine is equipped with the market's top grade components for the highest reliability and minimal maintenance.

- Main electrical components are SCHNEIDER.
- Main hydraulic components are VOITH.
- The hydraulic pump is of the internal gear type and make is VOITH.

CYBEND Controller: Esautomation S 675W – MULTI TOUCH

- 21" MULTI TOUCH display.
- Automatic calculation of bending point based on tooling and material data.
- Automatic calculation of bending force and crowning.
- Automatic calculation of sheet development.
- Automatic calculation of R and Z axes.
- Possibility to change working parameters to optimize the work piece.
- 2D graphic display of machine frame-work, work piece and tools.
- 2D graphic programming of work piece and tools.
- Automatic and manual optimization of the 2D bending sequence.
- Graphic visualization of roll formed bends.
- Simplified tool programming through standard formats.
- 3D image management generated by external CAD/CAM.
- Complete offline programming on a standard PC with use of a proper simulation software.
- USB port to store programs on pen drive.
- Ethernet connection.
- 2.5" hard disk to store tooling and programs data.
- Multilanguage visualization.

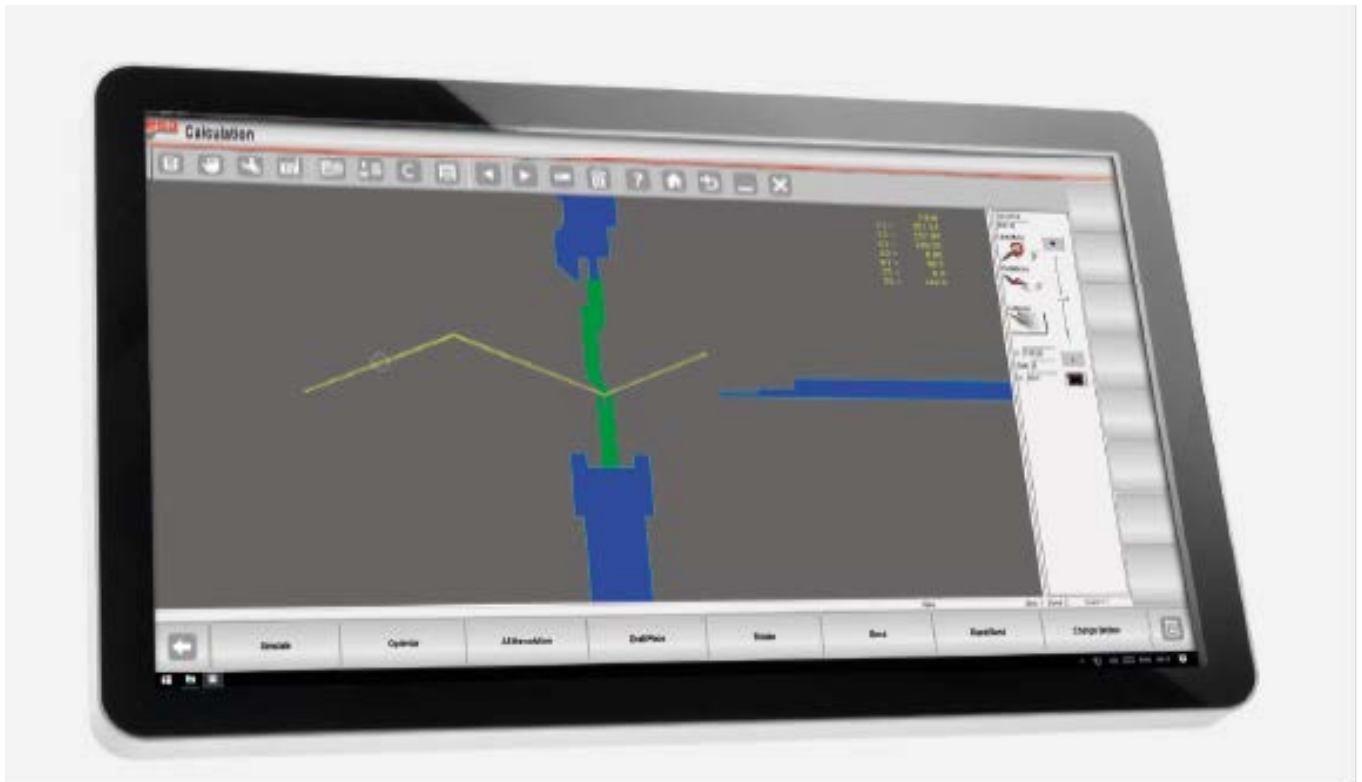

CYBEND Standard Accessories:

- Nr. 1 Control unit including the following:
 - o Double DESCENT/ASCENT pedal (The ascent pedal is required in case one does not require to reach the BDC).
 - o EMERGENCY pushbutton.
 - o ORANGE pushbutton for sheet metal thickness detection.
 - o BLUE button for emergency reset.
 - o Key selector for the “Box bending” function
- Protection of working area through laser beam type “LAZER SAFE” Mod. IRIS.
- Gap protection with opening doors and safety switches.
- Rear protection through light barriers.
- Automatic lubrication pump.
- Quick release intermediate clamps.
- Software KVARA PC for office offline programming.
- N° 2 Front support arms sliding on ball screw guides.
- Standard colour RAL 6018 – 7047 e RAL 9016
- USE AND MAINTENANCE MANUAL IN ENGLISH AND SPANISH.
- ELECTRICAL EQUIPMENT TEST REPORT CEI EN 60204-1:2006
- MACCHINE SUPPLIED ACCORDING TO CE STANDARDS.

CYBEND Additional equipment and features:

- 3 Additional controlled axes: X5, Z1 and Z2 axes to displace back gauge on one side and for longitudinal movement of b.g. fingers and controlled by rack and pinion. TOTAL AXES: 7 (Y1-Y2-X1-X5-R-Z1-Z2)
- 2 Pneumatically retractable rear supports.
- Double monitor S675 W - MULTI TOUCH 21 "with management of 3D images generated by external CAD / CAM and 2.5" HARD DISK.

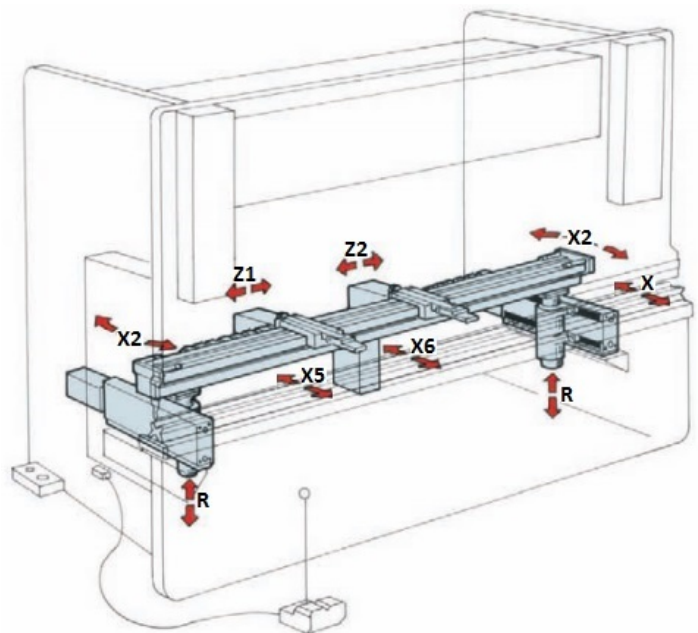

- Laser support brackets, for work area protection, motorized and with automatic positioning managed by the computer according to the type of punch used.



- WIRELESS control pulpit.



- Automatic tool changer set-up.
- WILA New Standard hydraulic punch clamping Mod. NSCL-I-HC-TY / ES and adjustment wedges.

Optional



- WILA New Standard hydraulic die clamping Mod. OB-I-HC / UPB.
Other versions for higher tonnages.

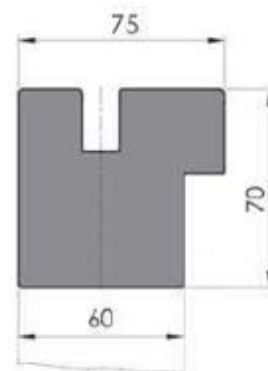

Fabricating Machinery, Inc. 214 688-0472
 ISO 9001 & ISO 14001

CY Bend	Hybrid series										
Model	Tons	OBL /BH	OH	Stroke	Bending Speeds	R	Z1Z2	Dims (lwh)	Weight	Motor	Beam ht
	US	inch	inch	inch	Fast/bend/return	inch		inches	Pounds	HP	inch
SPC-H-	Metric	mm	mm	mm	ipm & mm/s	mm		mm	kgs	kW	mm
2595	105	106.3/82.67	22	13.78	708/2.4-54/708	5.91	82.6	185x75x116.2	20,000	19	37.4
	95	2700/2100	560	350	300/1-23/300	150	2100	4700x1900x2950	9100	14	950
395	105	126/102.3	22	13.78	708/2.4-54/708	5.91	122	225x75x116.2	23,500	19	37.4
	95	3200/2600	560	350	300/1-23/300	150	3100	5700x1900x2950	10700	14	950
3130	140	126/102.3	22	13.78	708/2.4-54/708	5.91	82.6	185x79x118	27,600	27	37.4
	130	3200/2600	560	350	300/1-23/300	150	2100	4700x2000x3000	12550	20	950
4130	140	165.3/141.7	22	13.78	708/2.4-54/708	5.91	122	225x79x118	32,100	27	37.4
	130	4200/3600	560	350	300/1-23/300	150	3100	5700x2000x3000	14600	20	950
3180	200	126/102.3	22	13.78	708/2.4-54/708	5.91	82.6	185x81x118	33,000	28.5	37.4
	180	3200/2600	560	350	300/1-23/300	150	2100	4700x2050x3000	15000	21	950
4180	200	165.3/141.7	22	13.78	708/2.4-54/708	5.91	122	225x81x118	37,150	28.5	37.4
	180	4200/3600	560	350	300/1-23/300	150	3100	5700x2050x3000	16900	21	950
3245	270	126/102.3	24	15.748	708/2.4-54/708	9.84	82.6	185x87x130	43,500	38	39.37
	245	3200/2600	610	400	300/1-23/300	250	2100	4700x2200x3300	19800	28	1000
4245	270	165.3/141.7	24	15.748	708/2.4-54/708	9.84	122	225x87x130	49,500	38	39.37
	245	4200/3600	610	400	300/1-23/300	250	3100	5700x2200x3300	22500	28	1000
3345	380	126/102.3	25.98	15.748	472/2.4-30.68/472	9.84	82.6	185x91x138	51,700	45	39.37
	345	3200/2600	660	400	200/1-13/200	250	2100	4700x2300x3500	23500	33	1000
4345	380	165.3/141.7	25.98	15.748	472/2.4-30.68/472	9.84	122	225x91x138	61,600	45	39.37
	345	4200/3600	660	400	200/1-13/200	250	3100	5700x2300x3500	28000	33	1000
3445	490	126/102.3	25.98	15.748	472/2.4-30.68/472	9.84	82.6	185x95x140	58,300	70	39.37
	445	3200/2600	660	400	200/1-13/200	250	2100	4700x2400x3550	26500	52	1000
4445	490	165.3/141.7	25.98	15.748	472/2.4-30.68/472	9.84	122	225x95x140	70,400	70	39.37
	445	4200/3600	660	400	200/1-13/200	250	3100	5700x2400x3550	32000	52	1000

Gap 19.68 X-axis 31.5 X5, X6 5.91 Ram accuracy .000039"
 500 800 150 0.001

AS/ES Reversible gear pump Micrometric linear transducers for precision
 No heat build-up Laser-Safe for safety at hi-speeds
 Ram clamp 100mm standard 4350/3750mm 171/147" length/BH optional
 150 or 250 or 500mm optional.